



## **MULTI-STAGE HIGH PRESSURE COOLANT PUMPS**

- Your best choice for machine tool and industrial Coolant Pump with low cost, high performance and high reliability.
- The comprehensive range of Vertical Multi-Stage High Pressure Coolant Pumps as well as Under Water/Self Priming Coolant Pumps for your request.

# VERTICAL MULTI-STAGE HIGH PRESSURE COOLANT PUMPS

## SPECIAL FEATURES:

- Rigid and strong one-piece shaft.
- Heavy duty bearings greased for long life and easy maintenance.
- Motor above mounting flange ensures coolant not immersing into motor.
- Mechanical seal; increasing efficiency and assures no thrust float.
- Discharge available in either N.P.T./P.T.
- Stainless steel made enclosed impeller; increasing pump efficiency and flow volume.
- Multi-stages; up to 5 stages for pressure over 7 kgf/cm<sup>2</sup> staggered discharge ports equalize radial loads for increasing pump life.



- Temperature range: 0 ~ 80°C

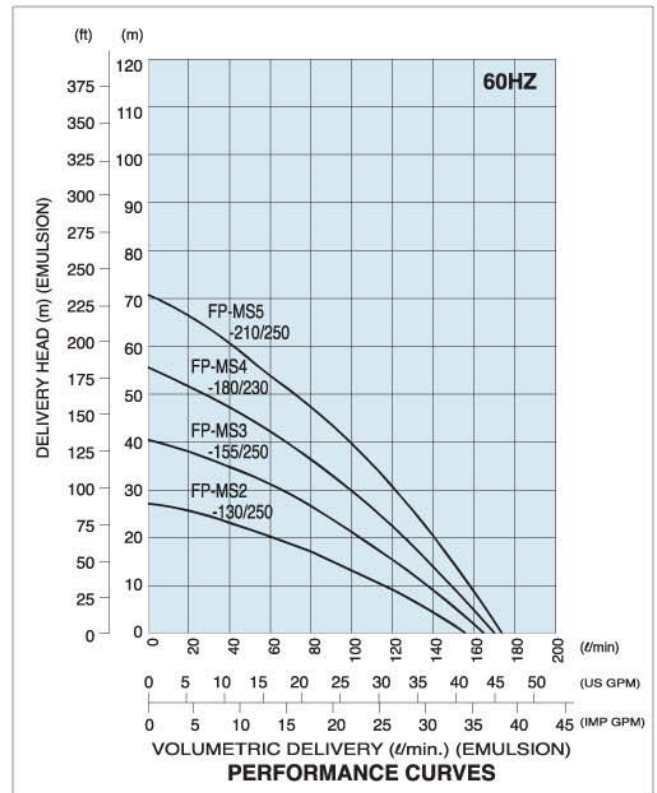
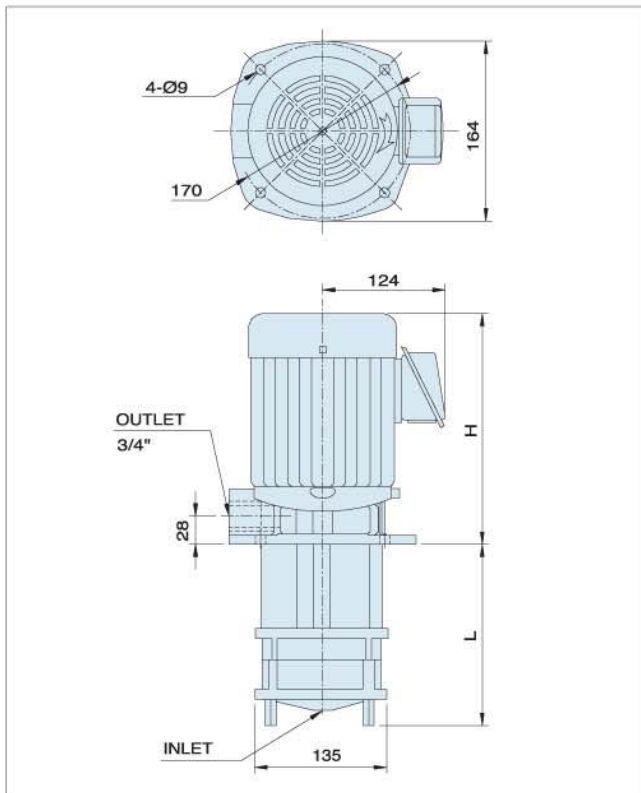

MODEL	STAGE	MOTOR (HP)	DIMENSIONS ( mm )				
			H	L			
FP-MS2-130 / 250	2	3/4	225	130	180	230	250
FP-MS3-155 / 250	3	1	245	155	200	250	
FP-MS4-180 / 230	4	1 1/4	270	180	230		
FP-MS5-210 / 250	5	1 1/2	270	210	250		

# UNDER WATER COOLANT PUMPS

- ALL PUMPS MADE ACCORDING TO EUROPEAN MANUFACTURING STANDARDS AND CONFORMING TO CE NORMS.
- LOW COST, HIGH PERFORMANCE AND HIGH RELIABILITY.

■ Temperature range: 0 ~ 80°C

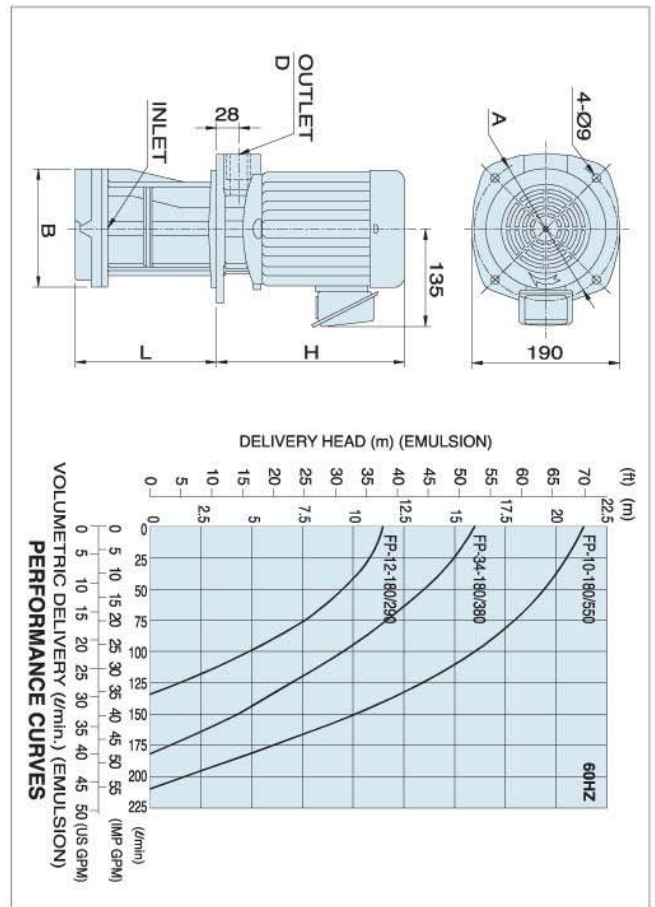
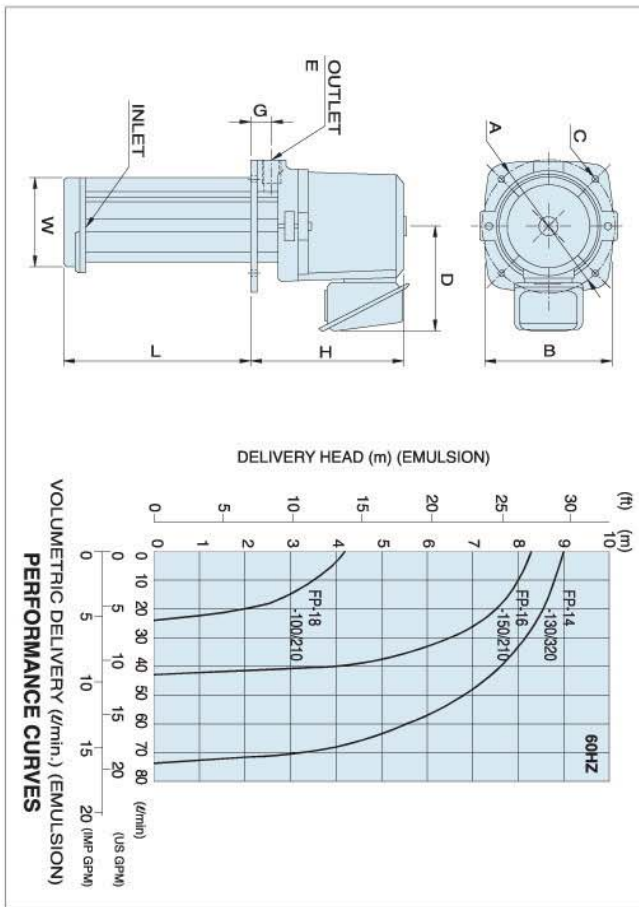

MODEL	MOTOR (HP)	DIMENSIONS ( mm )														
		A	B	C	D	E	G	H	W	L						
FP-18-100 / 210	1/8	128	128	7	110	3/8"	18	150	90	100	130	150	180	210		
FP-16-150 / 210	1/6	128	128	7	110	1/2"	18	150	100	150	210					
FP-14-120 / 320	1/4	158	165	8	125	1/2"	24	180	120	120	160	180	200	240	270	320

MODEL	MOTOR (HP)	DIMENSIONS ( mm )								
		A	B	D	H	L				
FP-12-180 / 290	1/2	170	135	3/4"	225	180	250	290		
FP-34-180 / 380	3/4	185	150	1"	255	180	250	280	380	
FP-10-180 / 550	1	185	150	1"	275	180	250	280	380	550



# SELF PRIMING COOLANT PUMPS



Special safety device & protection



Special water sealing



The complete fittings (i.e. harness, wire....etc.) are available for your choice

■ Temperature range: 0 ~ 80°C

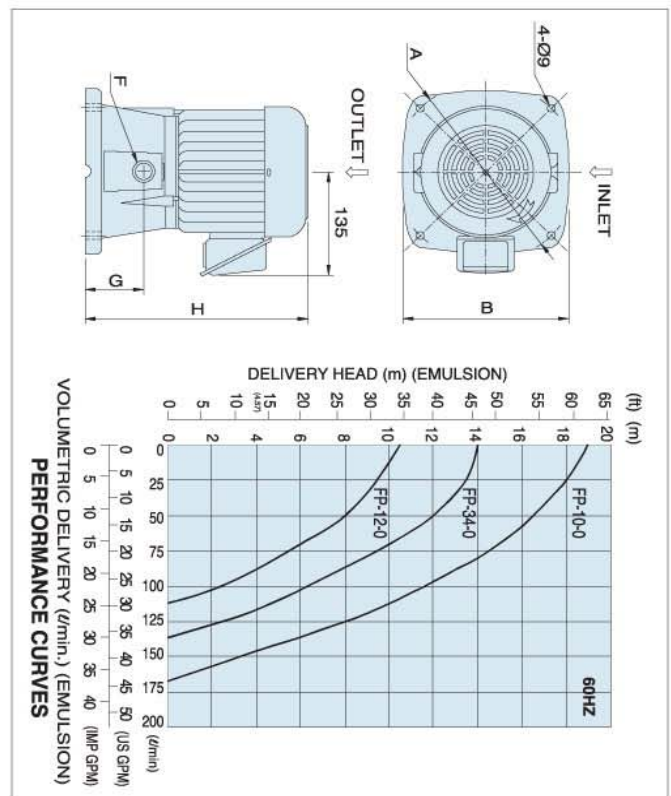
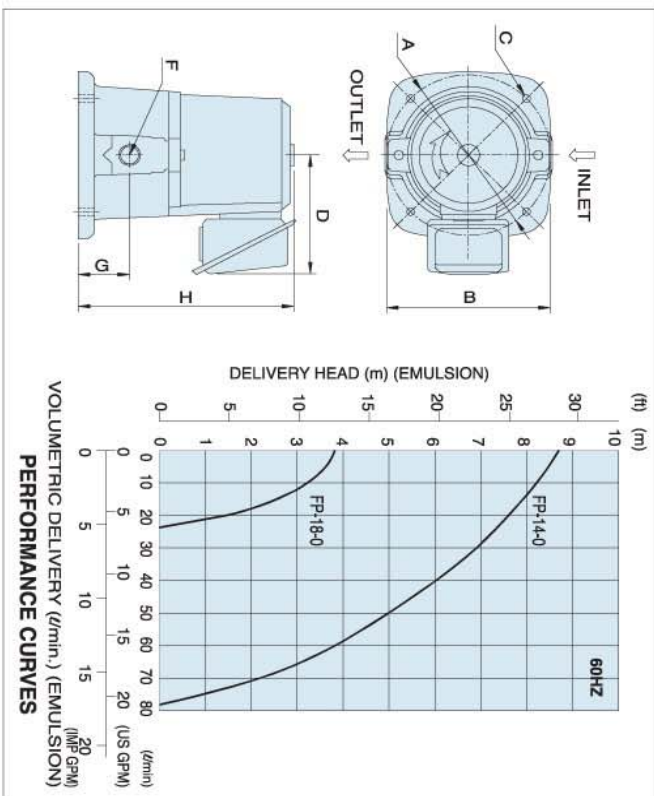

MODEL	MOTOR (HP)	DIMENSIONS ( mm )					
		A	B	C	D	F	G
FP-18-0	1/8	140	140	7	110	PT 3/8"	45
FP-14-0	1/4	185	185	8	125	PT 1/2"	65

MODEL	MOTOR (HP)	DIMENSIONS ( mm )				
		A	B	F	G	H
FP-12-0	1/2	215	195	3/4"	70	280
FP-34-0	3/4	220	200	1"	80	300
FP-10-0	1	220	200	1"	80	300

# COOLANT PUMP KITS



- The complete set of ready-made COOLANT PUMP KITS make your job and application easier.
- The comprehensive range of our COOLANT PUMP series all could be made to be the COOLANT PUMP KITS for your choice.
- Low cost and high efficiency; the best equipment for your machines.

## INCLUDING:

1. Coolant pump
2. Coolant tank
3. Connecting cable
4. Coolant hose kit w/magnetic base
5. Flexible conveying hose
6. Drain hose
7. Tool kits
8. ON/OFF switch (for 1ph)



ITEM	MODEL	FP-18-150K	FP-14-180K
Coolant pump (HPxL)		1/8 HP x150mm	1/4 HP x180mm
Tank size (LxWxH)		350x250x185mm	600x400x210mm
Volume of coolant tank		16 ℓ	50 ℓ
Connecting cable		2000mm	2000mm
Coolant hose kits w/magnetic base (øxL)		1/4"x330mm	3/8"x360mm
Flexible conveying hose (øxL)		3/8"x1500mm	1/2"x1500mm
Drain hose (øxL)		1"x300mm	1" x 300mm

• All specifications and designs are subject to change without prior notice.

# COOLANT PUMPS



**TOP PHOENIX  
INTERNATIONAL CORP.**  
Machinery Exporter & Importer

No. 48-3, Wayao Rd., Dali Dist.,  
Taichung City 412, Taiwan  
E-Mail: [sales@topphoenix.com.tw](mailto:sales@topphoenix.com.tw); [topphoenix24@gmail.com](mailto:topphoenix24@gmail.com);  
[top.phoenix@msa.hinet.net](mailto:top.phoenix@msa.hinet.net)  
<http://www.topphoenix.com.tw>  
Tel: 886-4-2406-5028 (Rep.) Fax: 886-4-2406-5019

Aug.-2020